

MAVERICK GENERATORS

Features:

- Digital control system with LCD display
- Maintenance-free battery with isolator switch
- Canopy with all-steel structure, strong and corrosion resistance
- Vibration isolators between the engine/alternator and base frame
- Integrated wiring design, in safety
- Base fuel tank for at least 8 hours running
- Equipped with an industrial class muffler
- Customization engine, designed for generators
- Equipped with 50°C radiator for all-weather
- Top lifting and steel base frame with forklift holes
- Drainage, radiator, engine oil.
- Complete protection functions and safety labels
- IP54 (soundproof sets), IP56 (control system)

Genset Ratings and Performance Data:

Open type	P-94	
Silent type (Soundproof)	P-94S	
Engine Brand	LOVOL	
Engine Make & Model:	1006TG1A	
Alternator Model:	JET224G	
Excitation Mode	Self-excitation	
Control System:	Digital Panel HGM420	
Noise Level@7m:	75—85db	
Frequency & Phase:	50Hz & 3 Phase	
Power Factor:	0.8	
Rated speed:/r/min	1500	
Fuel Tank Capacity: L	Open	150
	Silent	150
Fuel Consumption: l/hr (100% Load)	Prime	14.5
	Standby	16

Standard

ISO 8528



Design complies with ISO 8528 and GB/T2820-2009 Specifications

Output Rating:

50Hz

Genset Model	Prime		Standby	
	KVA	KW	KVA	KW
P-94/S	85	68	94	75

3-phase ratings at 0.8 power factor.

1-phase ratings at 1.0 power factor.

Rated Voltage (V)	Rated Current (A)
380	129.1

Engine specification:

Engine Manufacturer/Brand	LOVOL
Model	1006TG1A
Continuous Power (KW)	84.3
Standby Power (KW)	92.7
Number of Cylinders	6
Engine type	In-Line 4 Cycle, Water Cooled
Aspiration	Turbocharged aftercooled
Rotating speed	1500rpm
Engine cooling system	Water cooled
Speed governing system	Machinery
Starting method	24V DC
Displacement (L)	5.99
Type of Fuel	Diesel
Fuel Consumption(100%load)	14.5L/h
Bore×Stroke(mm)	100 x 127
Compression ratio	17.0. : 1
Lube capacity (L)	19
Type of Oil	15W40-CF4
Standardization	ISO3046, DIN6271



Alternator specification:

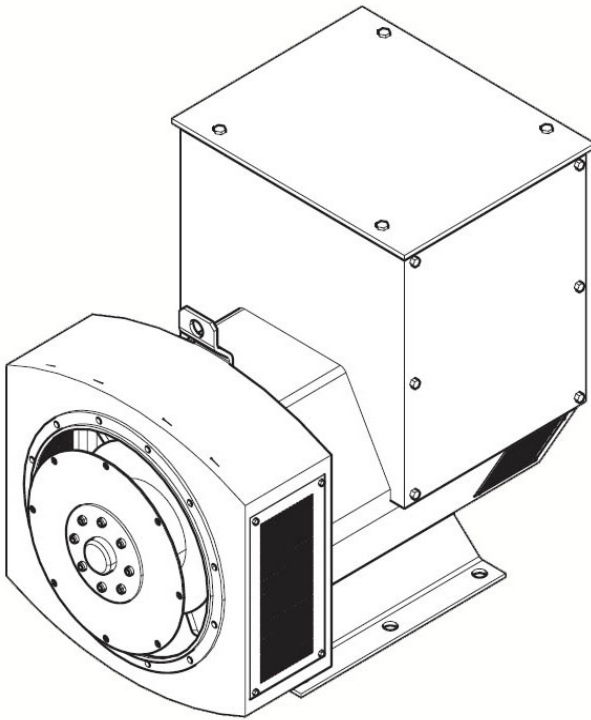

Alternator manufacturer/Brand	JET POWER
Alternator technology	Stamford Technology
Alternator model	JET224G
Alternator prime power (KW)	68
Alternator prime power (KVA)	85
Voltage V (optional)	120/230/240/380/400/415/440/480
Alternator frequency (Hz)	50/60
Excitation Mode	Brushless with AVR
Cooling fan	Cast alloy aluminum
Windings	100% copper
Insulation class	H Class
Winding pitch	2/3
Connect terminals	12
Drip proof	IP23
Altitude / Ambient temperature	≤ 1000m / ≤ 40°C
Overspeed	2250 RPM
Voltage regulation	±1.0%
Total harmonic	TGH / THCat no load < 1.5 % - on load < 5%
Telephone Interference	THF<2%;TIF<50
Standardization	GB755, VDE0530, NEMA ,MG1-22, MG1-32, IEC34, AS1359,GSA C22-100

Control System HGM420

HGM420 series genset controllers integrate digitization, intelligentization and network technology which are used for genset automation and monitor control system of single unit to achieve automatic start/stop, data measurement, alarm protection and “three remote” (remote control, remote measuring and remote communication; SG485 module must be fitted).

It fit with LCD display, optional languages interface (Chinese, English, Spanish, Turkish, Russian and French), and it is reliable and easy to use.



FEATURES

- Microprocessor control, with high stability and credibility
- Monitoring and measuring operational parameters of the mains supply and genset
- Indicating operation status, fault conditions, all parameters and alarms
- Multiple protections; multiple parameters display, like pressure, temp. etc.
- Manual, automatic and remote work mode selectable
- Real time clock for time and date display, overall runtime display, 250 log entries
- Overall power output display
- Integral speed/frequency detecting, telling status of start, rated operation, overspeed etc.
- Communication with PC via RS485 OR RS232 interface, using MODBUS protocol

Digital, intelligent control system allows easier operation.

Dimensions and Weights:

Silent Type

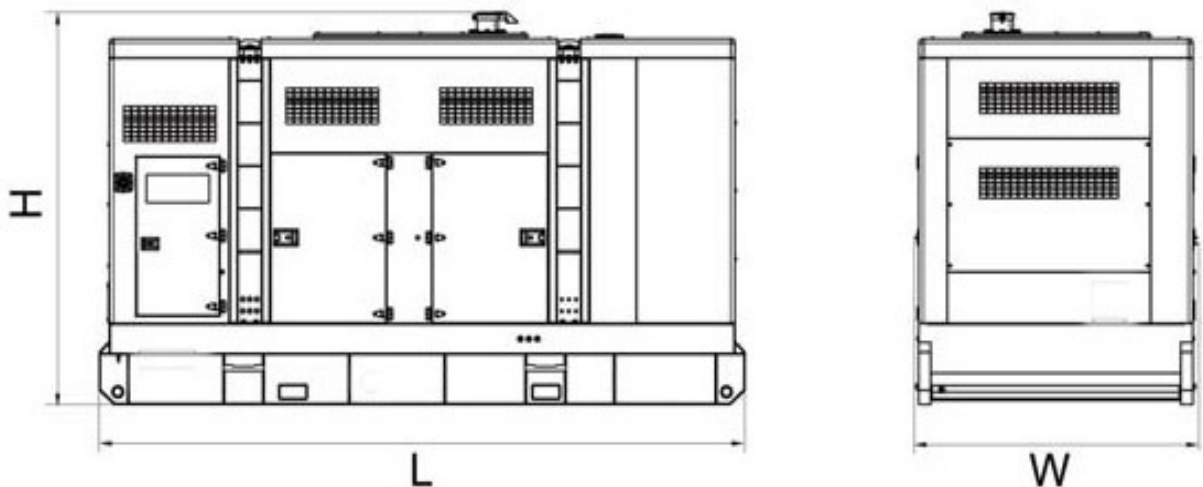

Genset Model	Length (L) mm	Width (W) mm	Height (H) mm	Weights Kg
P-94S	2800	1050	1550	1550

Dry = With Lube Oil Wet = With Lube Oil and Coolant

The weights are approximate and without fuel, only for your reference